

EQUESTRIANS WITH DISABILITIES HUNT SEAT EQUITATION (WALK/TROT) PATTERN I

LEGEND

.....	Walk
.....	Extended Walk
- - - -	Trot
- - - -	Extended Trot
- - - -	Sitting Trot
//////	Back

CLASS #504 AND #505

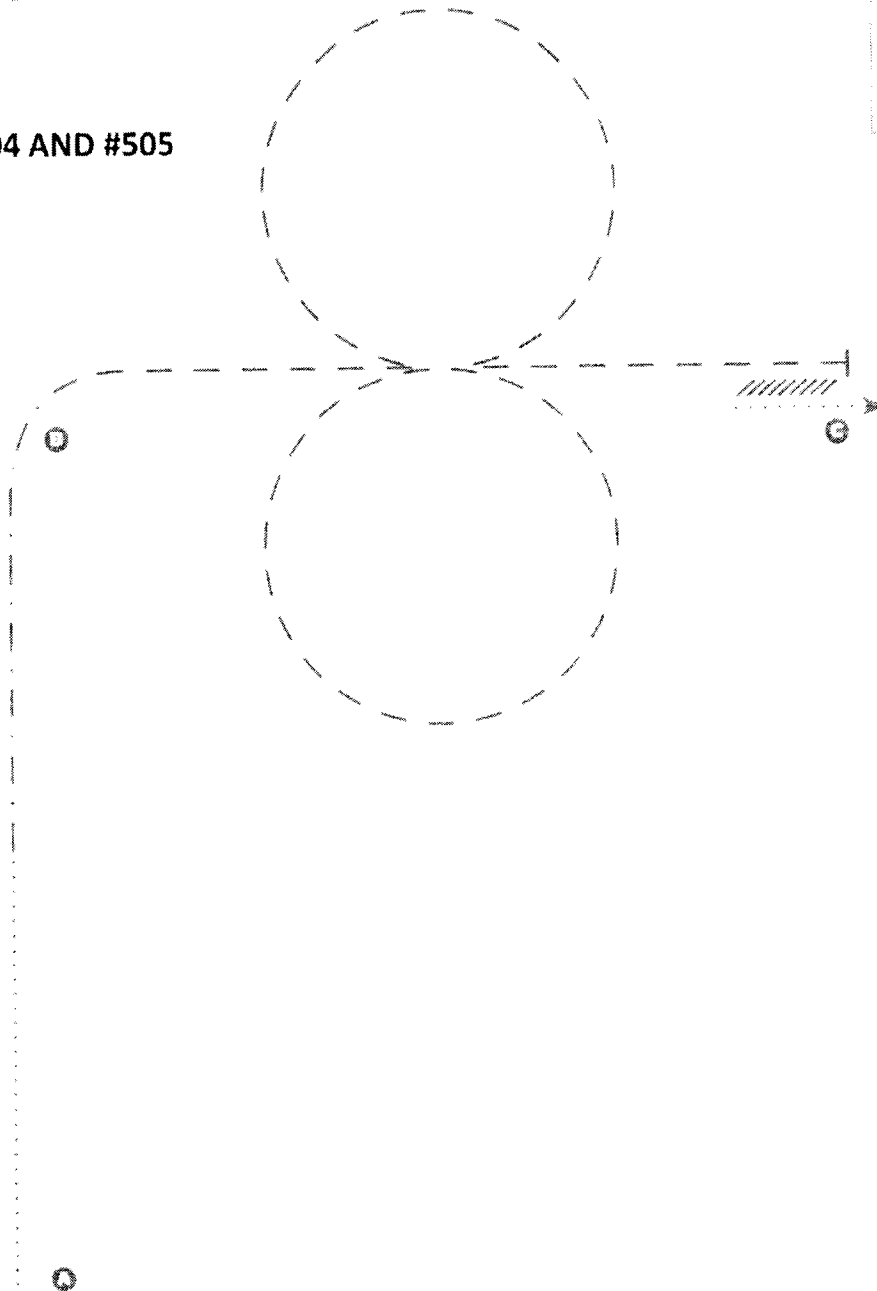

1. Be ready at A, walk approximately two horse lengths toward B
2. Sitting trot to B
3. At B, posting trot left diagonal toward C
4. Trot a circle to the right
5. Close circle, change diagonals and trot a circle to the left, continue trotting to C
6. At C, halt
7. Back approximately one horse length, walk forward over tracks, pattern is complete

Note: Cones should be set in a manner that is the most appropriate for the class, arena and maneuvers.

EQUESTRIANS WITH DISABILITIES SHOWMANSHIP (WALK/TROT-JOG) PATTERN I

LEGEND	
.....	Walk
.....	Extended Walk
-----	Trot
-----	Extended Trot
//////	Back

CLASS #246

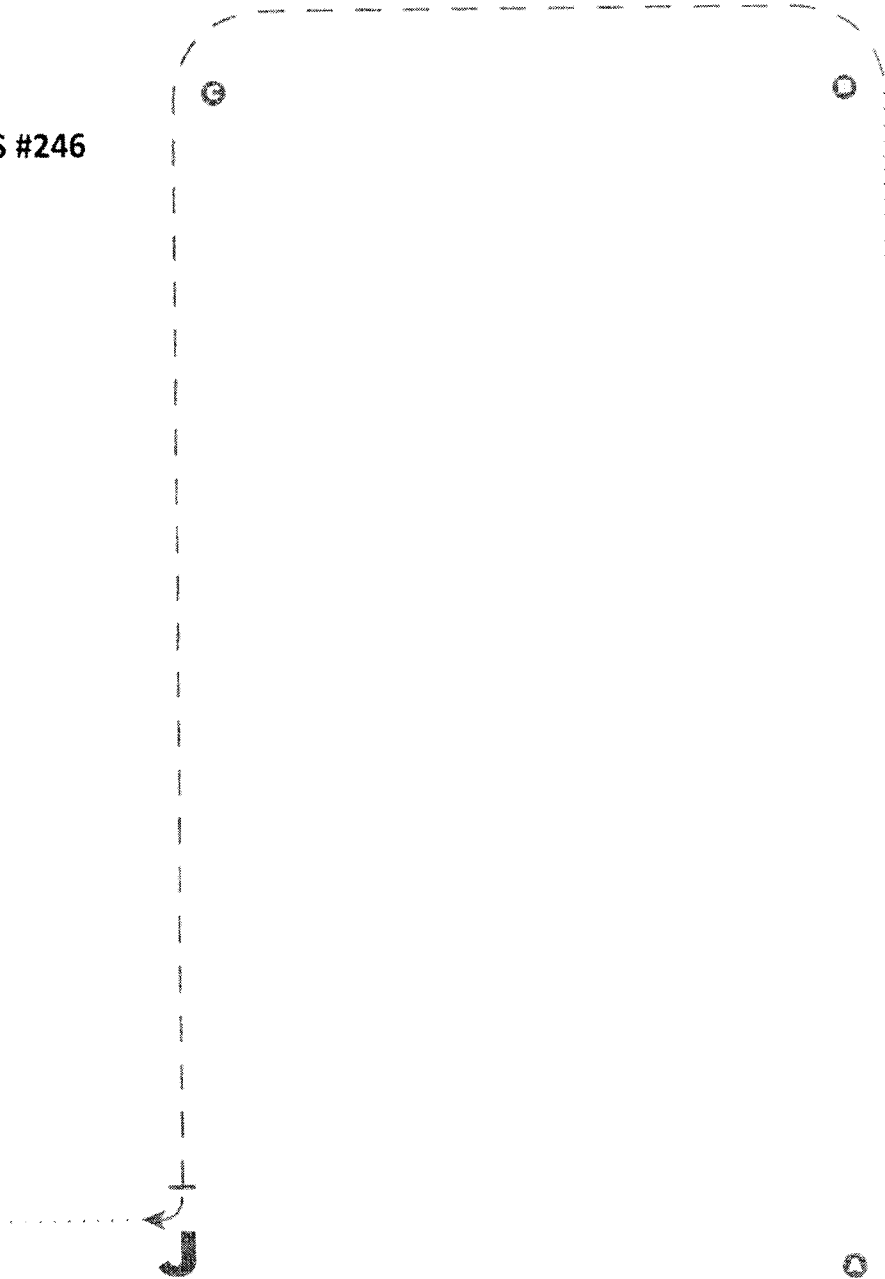

1. Be ready at A, walk from A to B
2. At B, trot around B to C
3. Continue trotting around C to judge
4. At judge, stop, set up
5. Inspection
6. When dismissed, 90° turn and walk away, pattern is complete

Note: Cones should be set in a manner that is the most appropriate for the class, arena and maneuvers.

EQUESTRIANS WITH DISABILITIES SHOWMANSHIP (WALK ONLY) PATTERN I

LEGEND

- Walk
- Extended Walk
- /////// Trot

CLASS #245

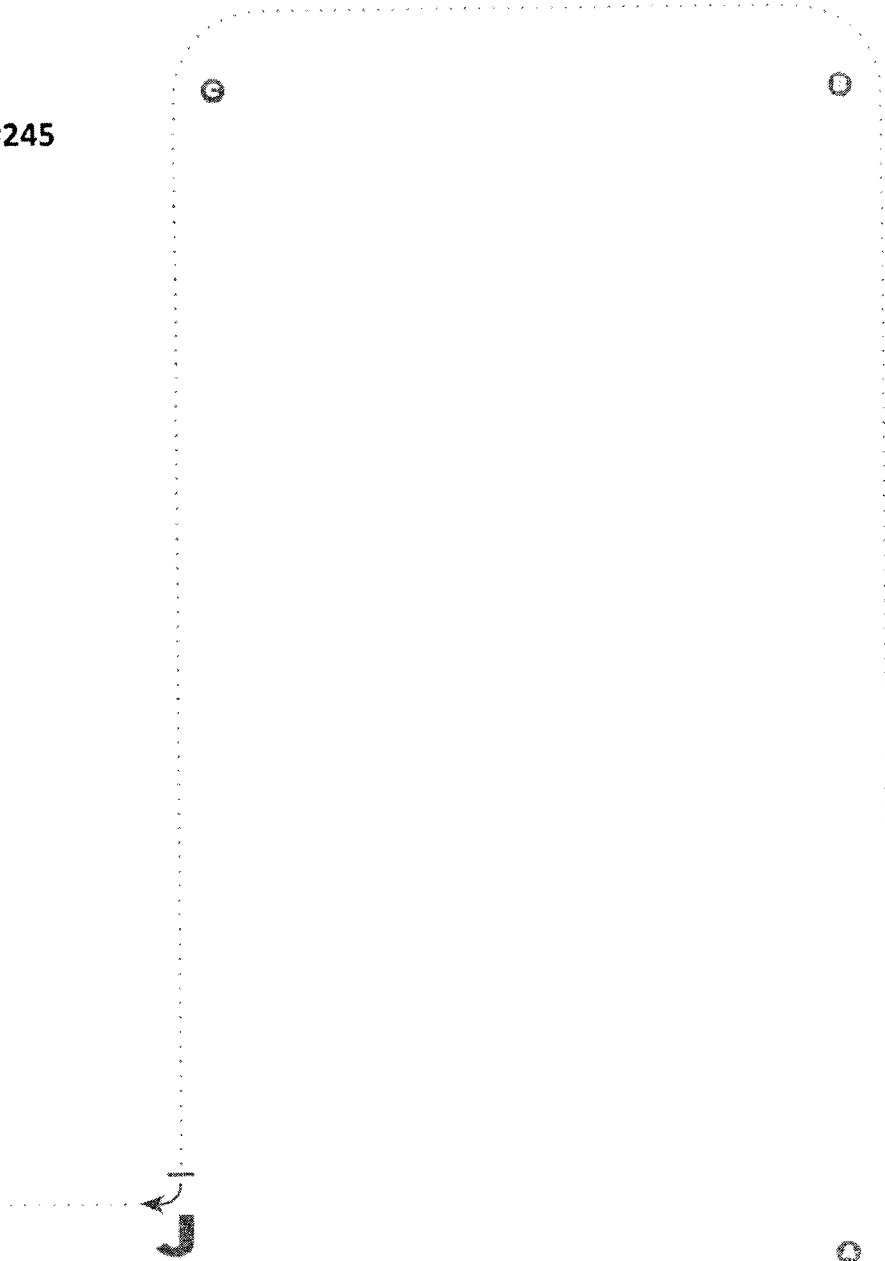

1. Be ready at A, walk from A to B
2. Continue walking around B to C
3. Continue walking around C to judge
4. At judge, stop, set up
5. Inspection
6. When dismissed, 90° turn and walk away, pattern is complete

Note: Cones should be set in a manner that is the most appropriate for the class, arena and maneuvers.

Dal-Worth ApHC Spring Spectacular

Walk/Trot Showmanship (198,199,200,201,202,247,248,249)

Show Date:

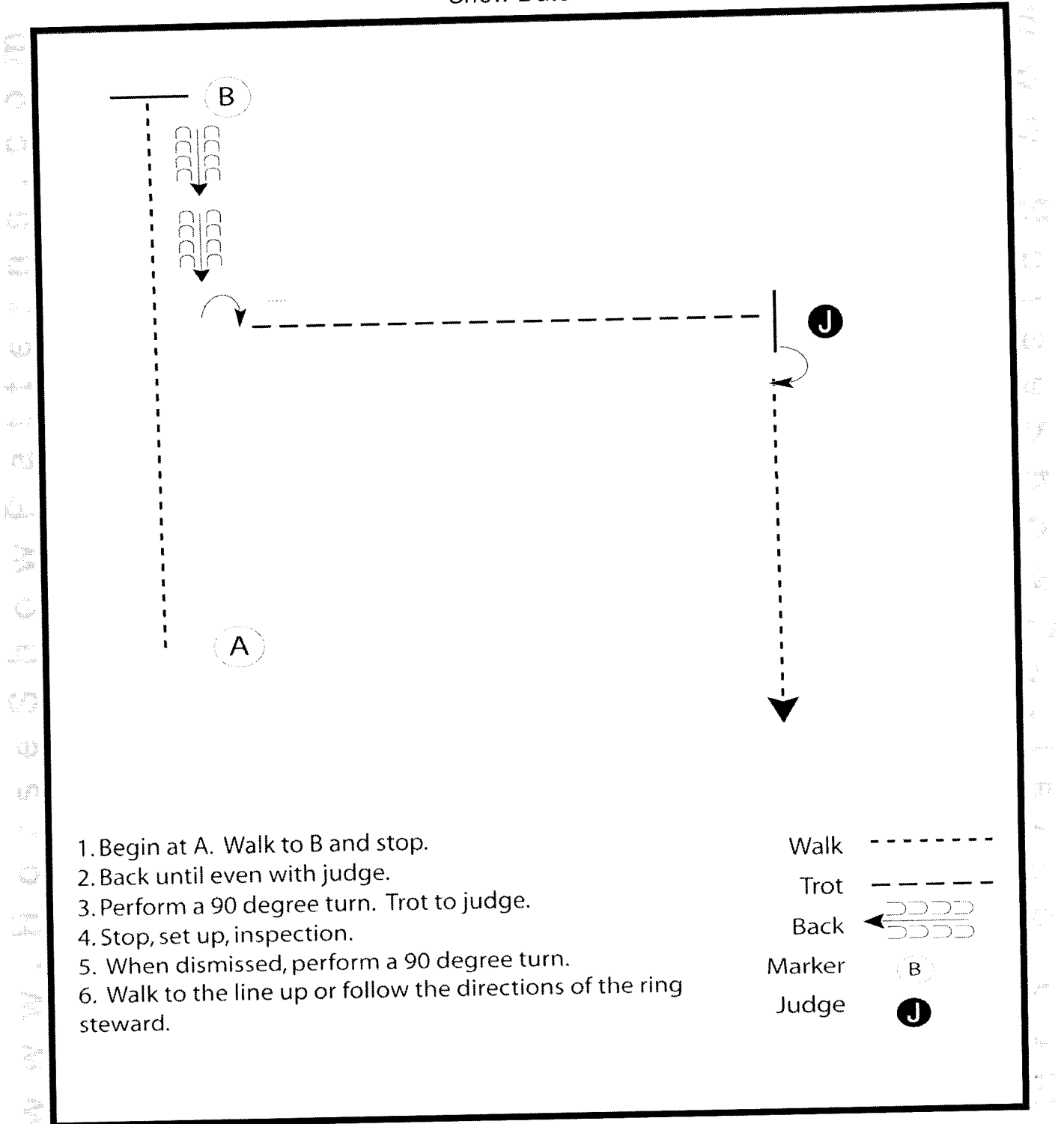

1. Begin at A. Walk to B and stop.
2. Back until even with judge.
3. Perform a 90 degree turn. Trot to judge.
4. Stop, set up, inspection.
5. When dismissed, perform a 90 degree turn.
6. Walk to the line up or follow the directions of the ring steward.

- Walk -----
- Trot -----
- Back ←-----
- Marker (B)
- Judge (J)

[S/WT-4]

Pattern Provided by:

Judges

Dal-Worth ApHC Spring Spectacular

Showmanship (Classes #203 through #216)

Show Date:

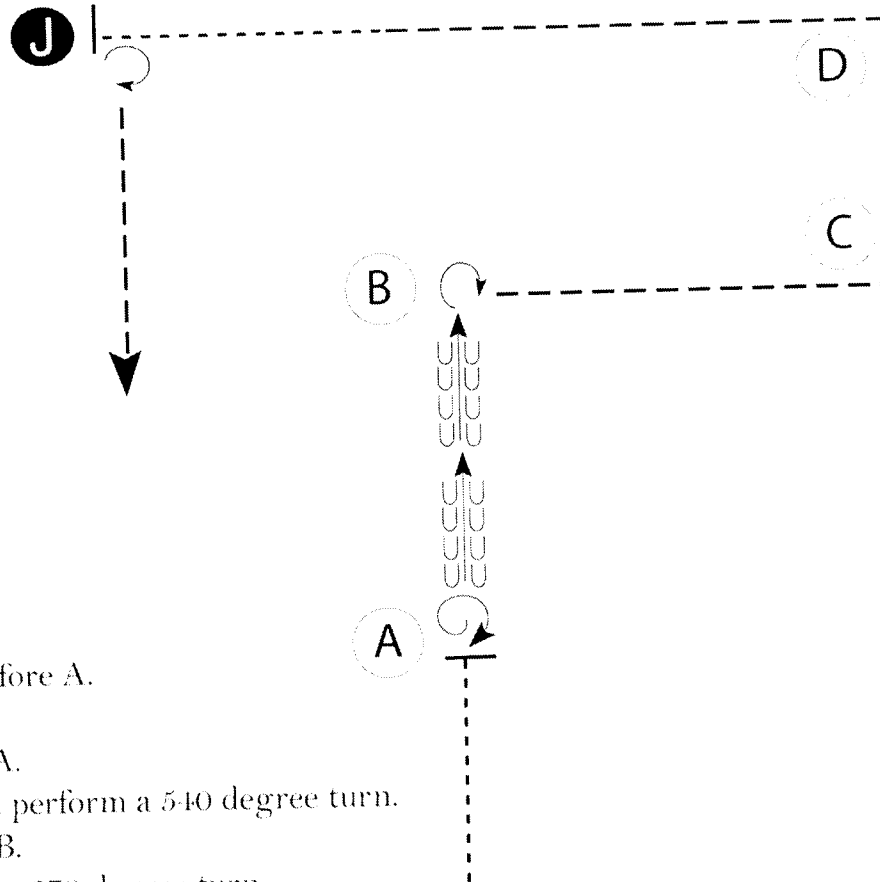

Be ready before A.

1. Walk to A.
2. Stop and perform a 540 degree turn.
3. Back to B.
4. Perform a 270 degree turn.
5. Trot square corners around C and D toward judge.
6. When even with B, break to a walk.
7. Walk to judge.
8. Stop and set up for inspection.
9. When dismissed, perform a 270 degree turn and trot straight away from judge.

Walk	-----
Trot	----- -----
Back	←----- ←-----
Marker	ⓑ
Judge	ⓐ

Follow the instructions of your ring steward.

[S/3-49]

Pattern Provided by:

Judges

Dal-Worth ApHC Spring Spectacular

Showmanship (#243,244 and #250 through #257)

Show Date:

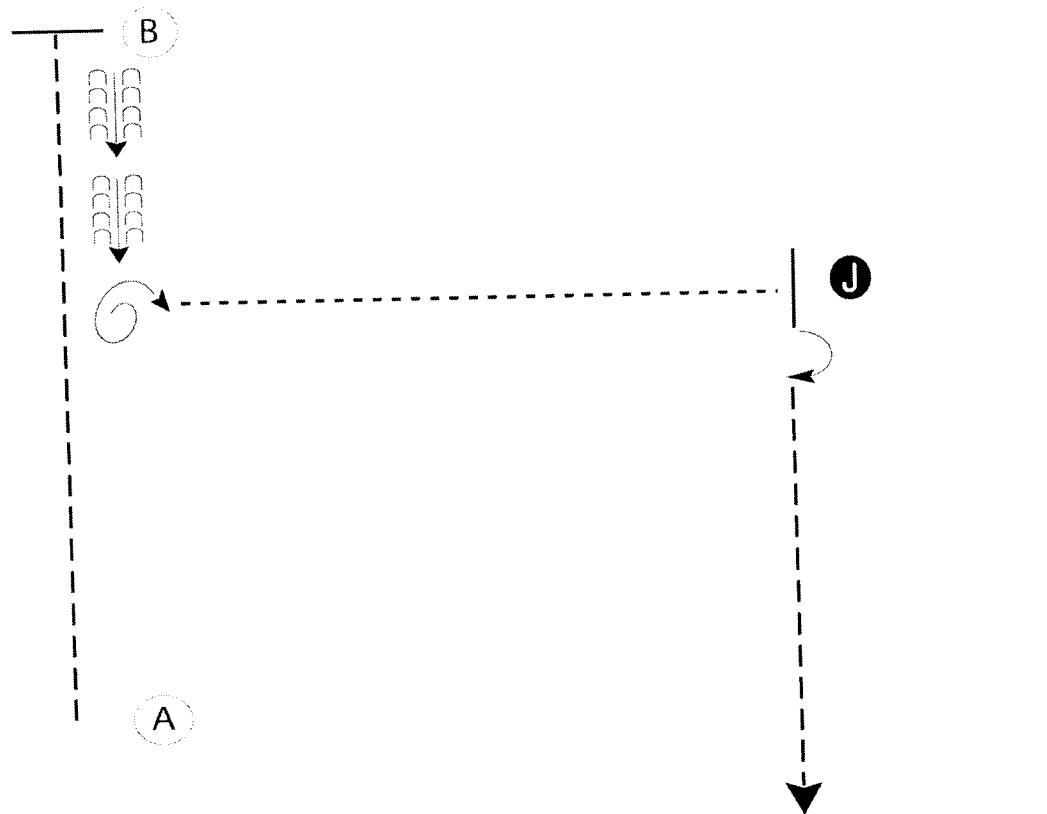

1. Begin at A. Trot to B and stop.
2. Back until even with judge.
3. Perform a 450 degree turn. Walk to judge.
4. Stop, set up, inspection.
5. When dismissed, perform a 90 degree turn.
6. Trot to the line up or follow the directions of the ring steward.

Walk	-----
Trot	- - - - -
Back	← ○○○○ ○○○○
Marker	(B)
Judge	ⓙ

[S/2-29]

Pattern Provided by:

Judges

Dal-Worth ApHC Spring Spectacular

BAREBACK HORSEMANSHIP (ALL AGES)

Show Date: May 17-19, 2024

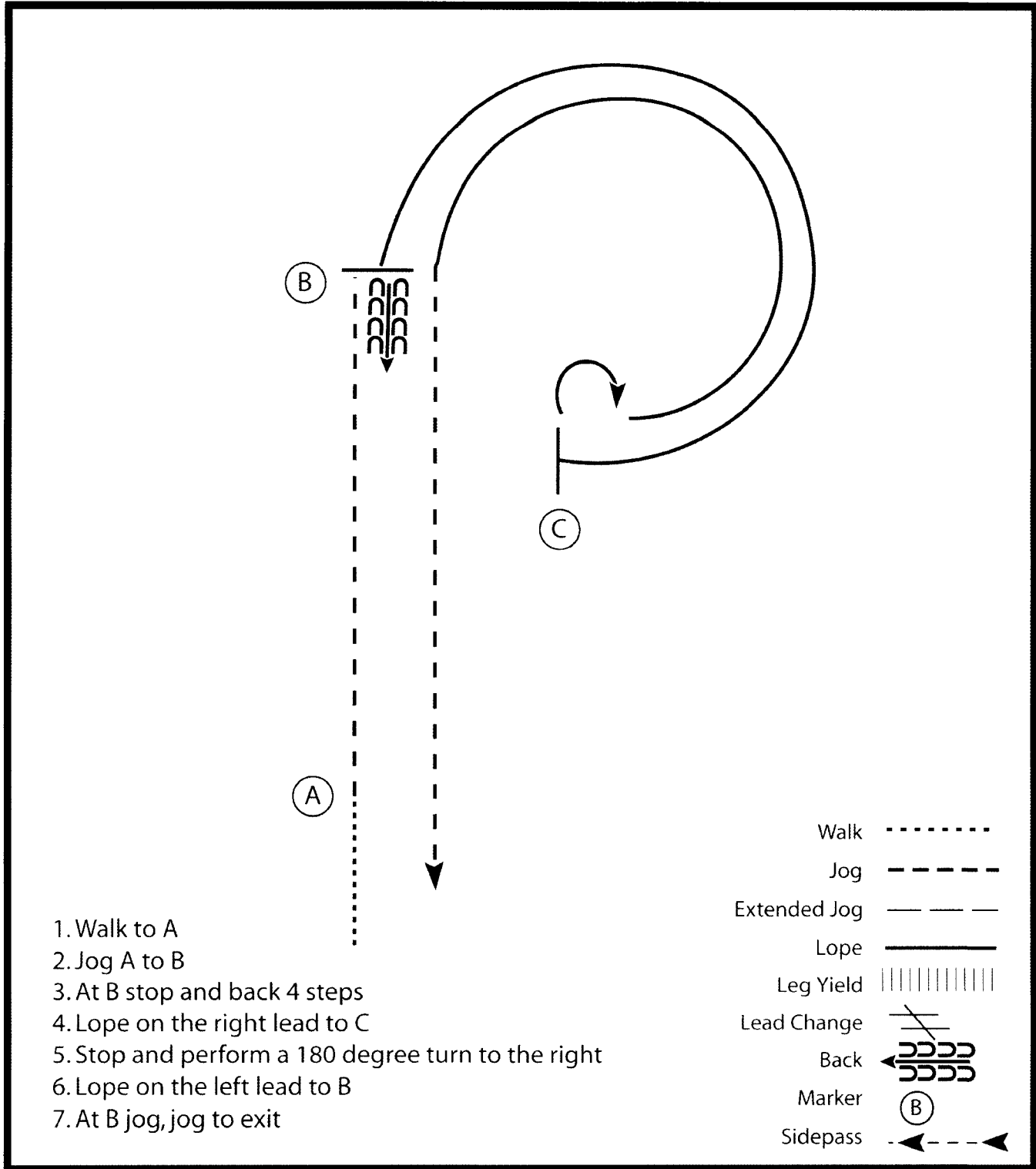

[WH/2-49]

Pattern Provided by:

Judges

Dal-Worth ApHC Spring Spectacular

WALK TROT HORSEMANSHIP (ALL AGES)

Show Date: May 17-19, 2024

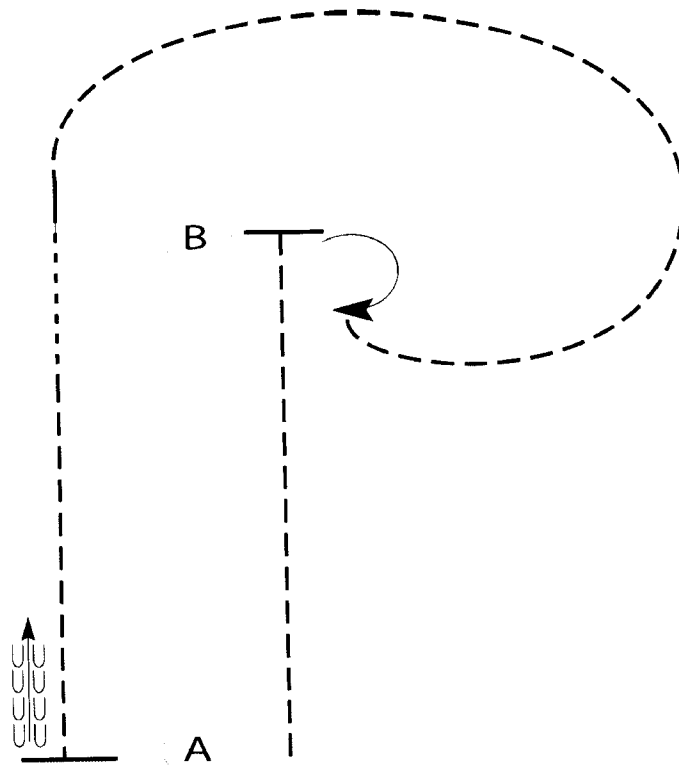

Be ready at A.

1. Jog to B.
2. Turn 180 degrees to the right.
3. Jog back around to B.
4. At B, break to the walk.
5. Walk approximately 10 feet.
6. Jog to A.
7. Stop at A and back approximately one horse length.

Follow the instructions of your ring steward.

Walk	-----
Jog	- - - - -
Extended Jog	— — — —
Lope	—————
Leg Yield	+++++
Lead Change	↖ ↘
Back	← ⊞ ⊞ ⊞ ⊞ ⊞
Marker	⊞
Sidepass	← ⊞ ⊞ ⊞ ⊞ ⊞ →

[WH/WT-43]

Pattern Provided by:

Judges

Dal-Worth ApHC Spring Spectacular

WESTERN HORSEMANSHIP (Class #338, 351 - 366)

Show Date: May 17-19, 2024

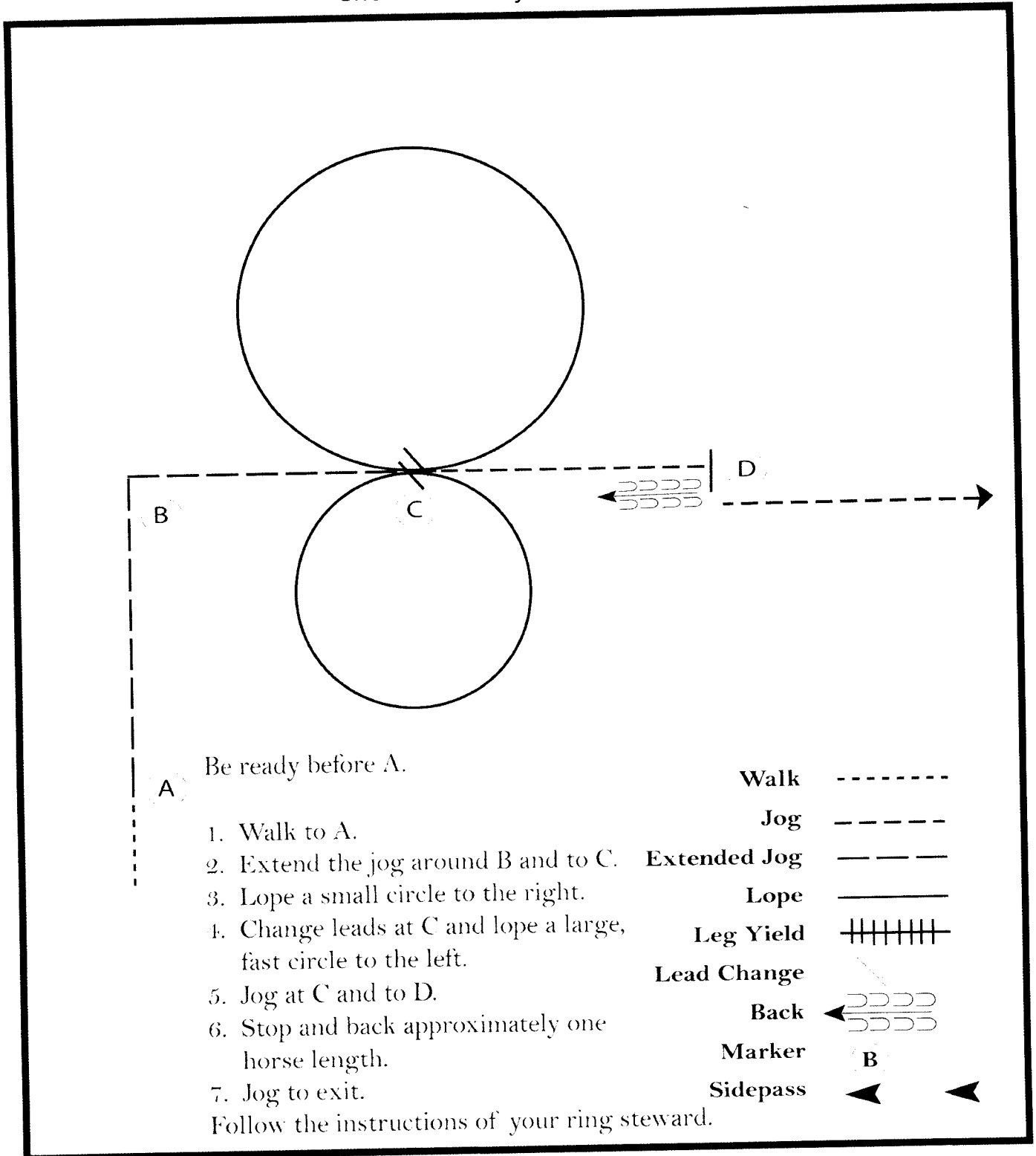

[WH/3-65]

Pattern Provided by:

Judges

Dal-Worth ApHC Spring Spectacular

WESTERN HORSEMANSHIP (Class #367 - 372)

Show Date: May 17-19, 2024

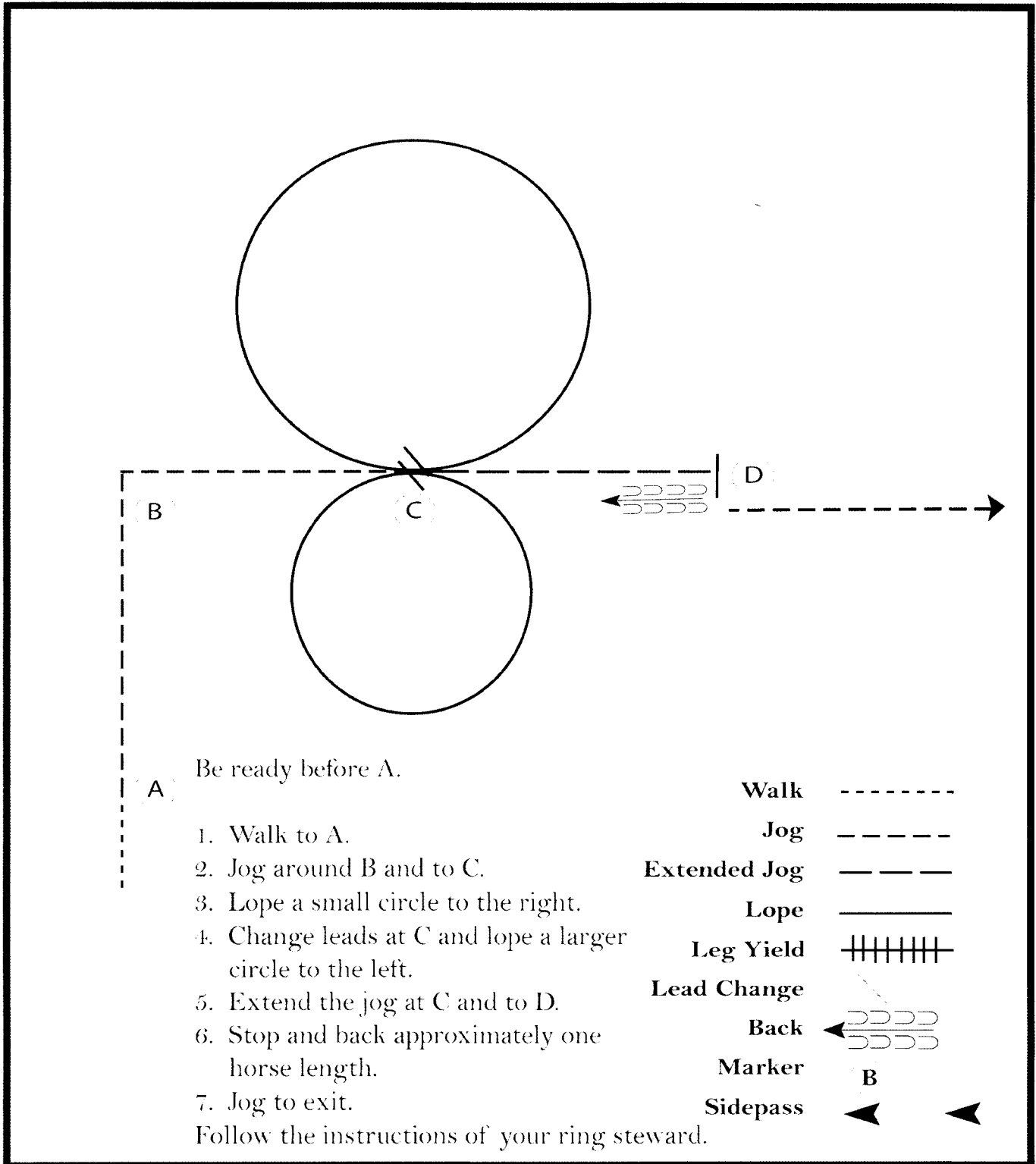

[WH/2-65]

Pattern Provided by:

Judges

Dal-Worth ApHC Spring Spectacular

Walk/Trot Hunt Seat Equitation (#506 through #514)

Show Date:

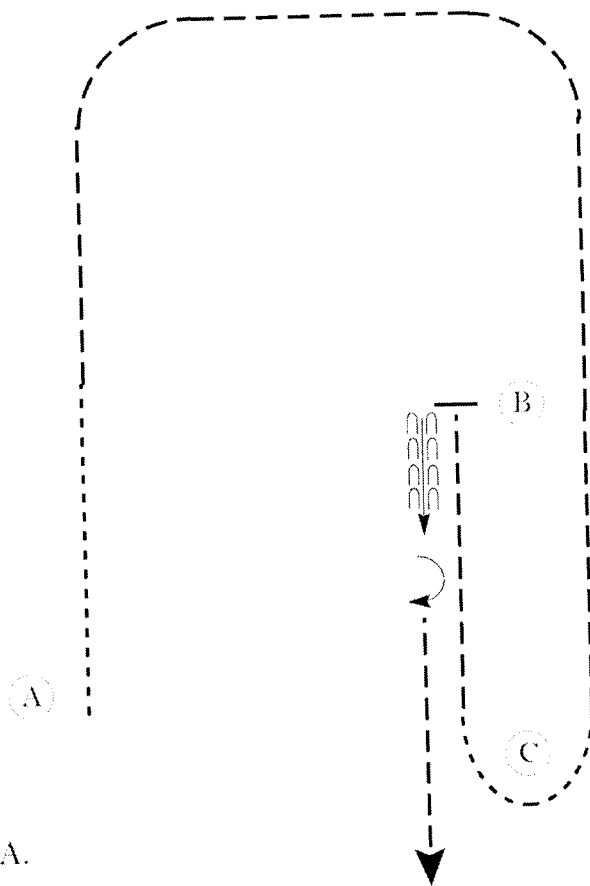

Be ready at A.

1. Walk until even with B.
2. Trot on the left diagonal to B.
3. Sitting trot from B to C.
4. Walk around C.
5. Trot on the right diagonal to B.
6. Stop and back approximately one horse length.
7. Perform a 180 degree turn to the right on the hindquarters and trot to exit.

Walk	-----
Trot	- - - - -
Extended Trot	-----
Canter	-----
Leg Yield	
Lead Change	↔
Back	←○○○○
Marker	⊙ B
Sidepass	◀ ◀
Hand Gallop	-----

[HSE/WT-38]

Pattern Provided by:

Judges

Dal-Worth ApHC Spring Spectacular

Hunt Seat Equitation (#515 through #536)

Show Date:

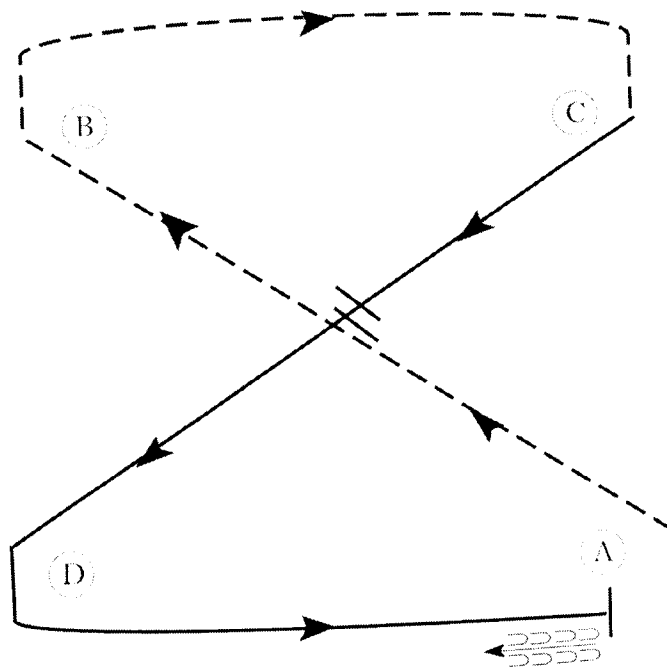

Be ready at A.

1. Posting trot on the right diagonal 1/2 way to B.
2. Change diagonals and post the trot to B.
3. Sitting trot to C.
4. Canter on the right lead 1/2 way to D.
5. Change leads and canter to and around D to A.
6. Halt at A and back approximately one horse length.

Exit at a sitting trot.

Walk	-----
Trot	-----
Extended Trot	-----
Canter	-----
Leg Yield	
Lead Change	
Back	←←←←←
Marker	Ⓚ
Sidepass	←←
Hand Gallop	-----

[HSE/3-24]

Pattern Provided by:

Judges

Dal-Worth ApHC Spring Spectacular

REINING (OPEN)

Show Date: May 17-19, 2024

REINING PATTERN 10

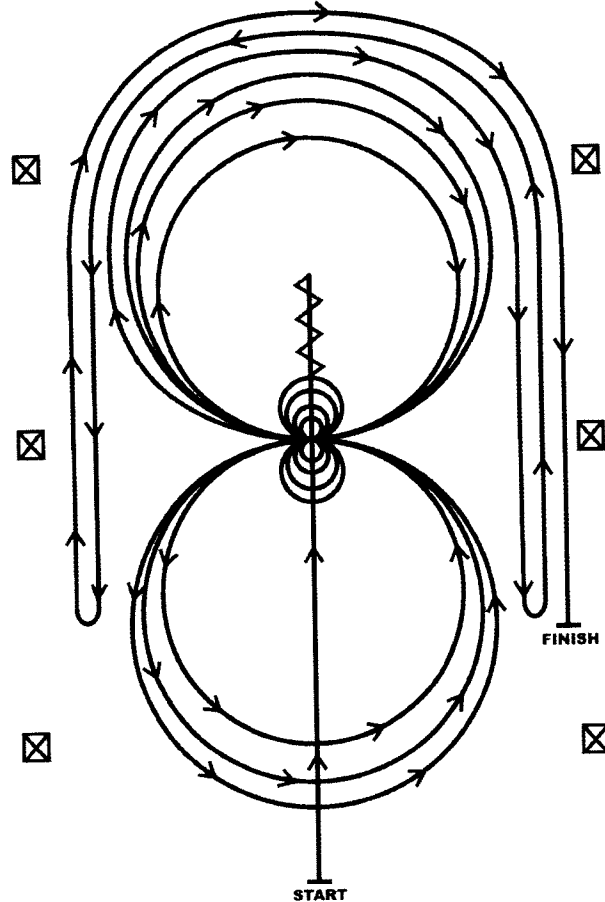

1. Run past the center marker and do a sliding stop. Back up to the center of the arena or at least ten feet (three meters). Hesitate.
2. Complete four spins to the right. Hesitate.
3. Complete four and one-quarter spins to the left so that the horse is facing the left wall or fence. Hesitate.
4. Beginning on the right lead, complete three circles to the right: the first two circles large and fast, the third circle small and slow. Change leads at the center of the arena.
5. Complete three circles to the left: the first circle small and slow, the next two circles large and fast. Change leads at the center of the arena.
6. Begin a large circle to the right but do not close this circle. Run down the right side of the arena past the center marker and do a left rollback at least twenty feet (six meters) from the wall or fence—no hesitation.
7. Continue back around the previous circle but do not close this circle. Run down the left side of the arena past the center and do a right rollback at least twenty feet (six meters) from the wall or fence—no hesitation.
8. Continue back around previous circle but do not close this circle. Run down the right side of the arena past the center marker and do a sliding stop at least twenty feet (six meters) from the wall or fence. Hesitate to demonstrate completion of the pattern.

[R/AQHAP-10]

Pattern Provided by:

Judges

Dal-Worth ApHC Spring Spectacular

REINING (NP and AM)

Show Date: May 17-19, 2024

REINING PATTERN II

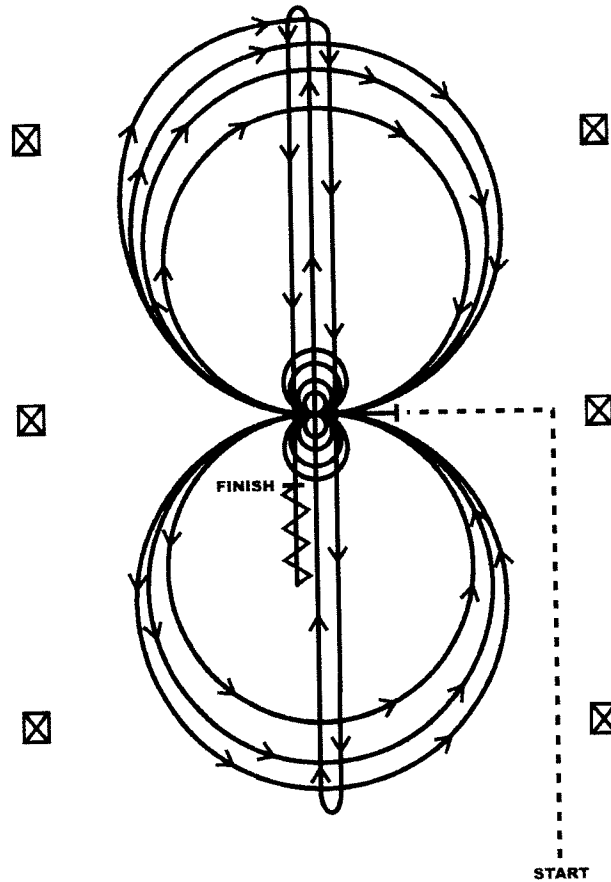

Horses must jog to the center of the arena. Horses must walk or stop prior to starting the pattern. Beginning at the center of the arena facing the left wall or fence.

1. Complete four spins to the left. Hesitate.
2. Complete four spins to the right. Hesitate.
3. Beginning on the right lead complete three circles to the right: the first circle small and slow; the next two circles large and fast. Change leads at the center of the arena.
4. Complete three circles to the left: the first circle small and slow; the next two circles large and fast. Change leads at the center of the arena.
5. Begin a large circle to the right, but do not close this circle. Run down the center of the arena past the end marker and do a right rollback—no hesitation.
6. Run up the middle to the opposite end of the arena past the end marker and do a left rollback—no hesitation.
7. Run past the center marker and do a sliding stop. Back up to the center of the arena or at least ten feet (three meters). Hesitate to demonstrate completion of the pattern.

[R/AQHAP-11]

Pattern Provided by:

Judges

Dal-Worth ApHC Spring Spectacular

REINING (YOUTH (PthA Pattern 14))

Show Date: May 17-19, 2024

REINING PATTERN A

Approved only for Level I Youth & Amateur, Youth 13 & Under

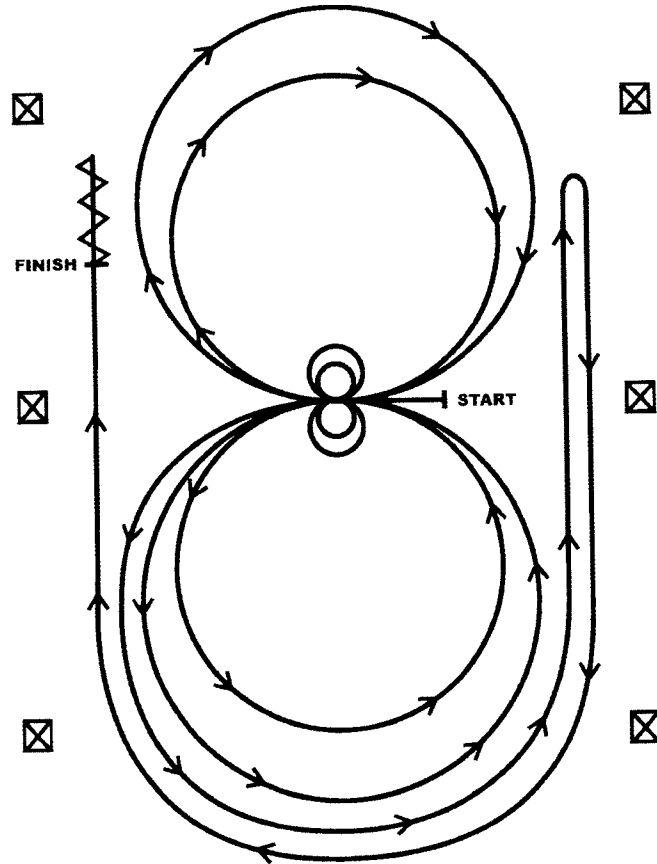

Horses may walk or jog to the center of the arena. Horses must walk or stop prior to starting the pattern. Beginning at the center of the arena facing the left wall or fence.

1. Beginning on the left lead, complete two circles to the left. Stop at the center of the arena. Hesitate.
2. Complete two spins to the left. Hesitate.
3. Beginning on the right lead, complete two circles to the right. Stop at the center of the arena. Hesitate.
4. Complete two spins to the right. Hesitate.
5. Beginning on the left lead, go around the end of the arena, run down the right side of the arena past center marker, stop and roll back right.
6. Continue around the end of the arena to run down the left side of the arena past the center marker. Stop. Back up. Hesitate to demonstrate completion of the pattern. See the Judges' Guide for a summary of other allowances made in the Handbook.

[R/AQHAP-A]

Pattern Provided by:

Judges

Dal-Worth ApHC Spring Spectacular

WALK-TROT RANCH RIDING - ALL (

Show Date: May 17-19, 2024

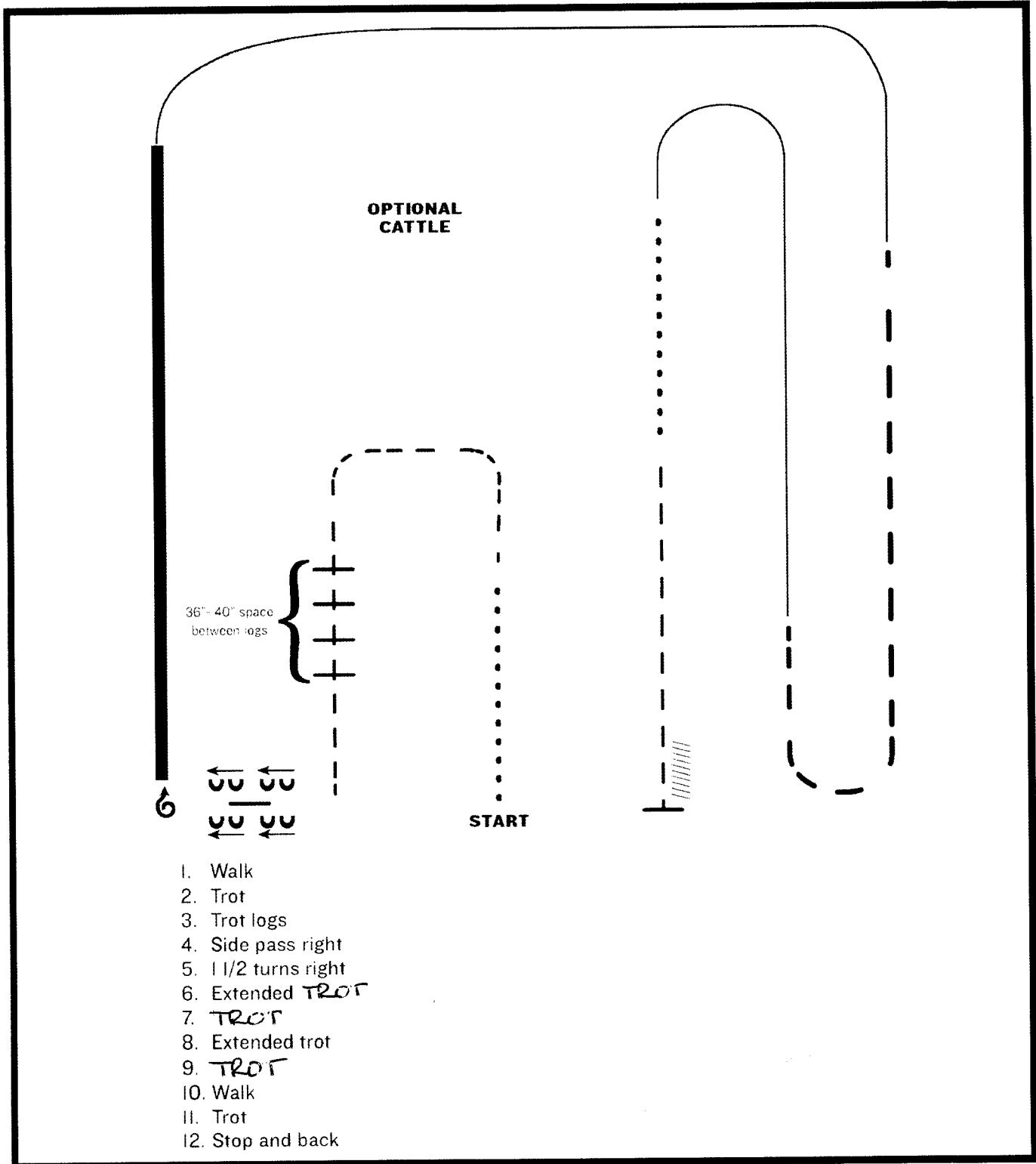

[RR/AQHA-12]

Pattern Provided by:

Judges

Dal-Worth ApHC Spring Spectacular

RANCH RIDING (Class #34, 41-45)

Show Date: May 17-19, 2024

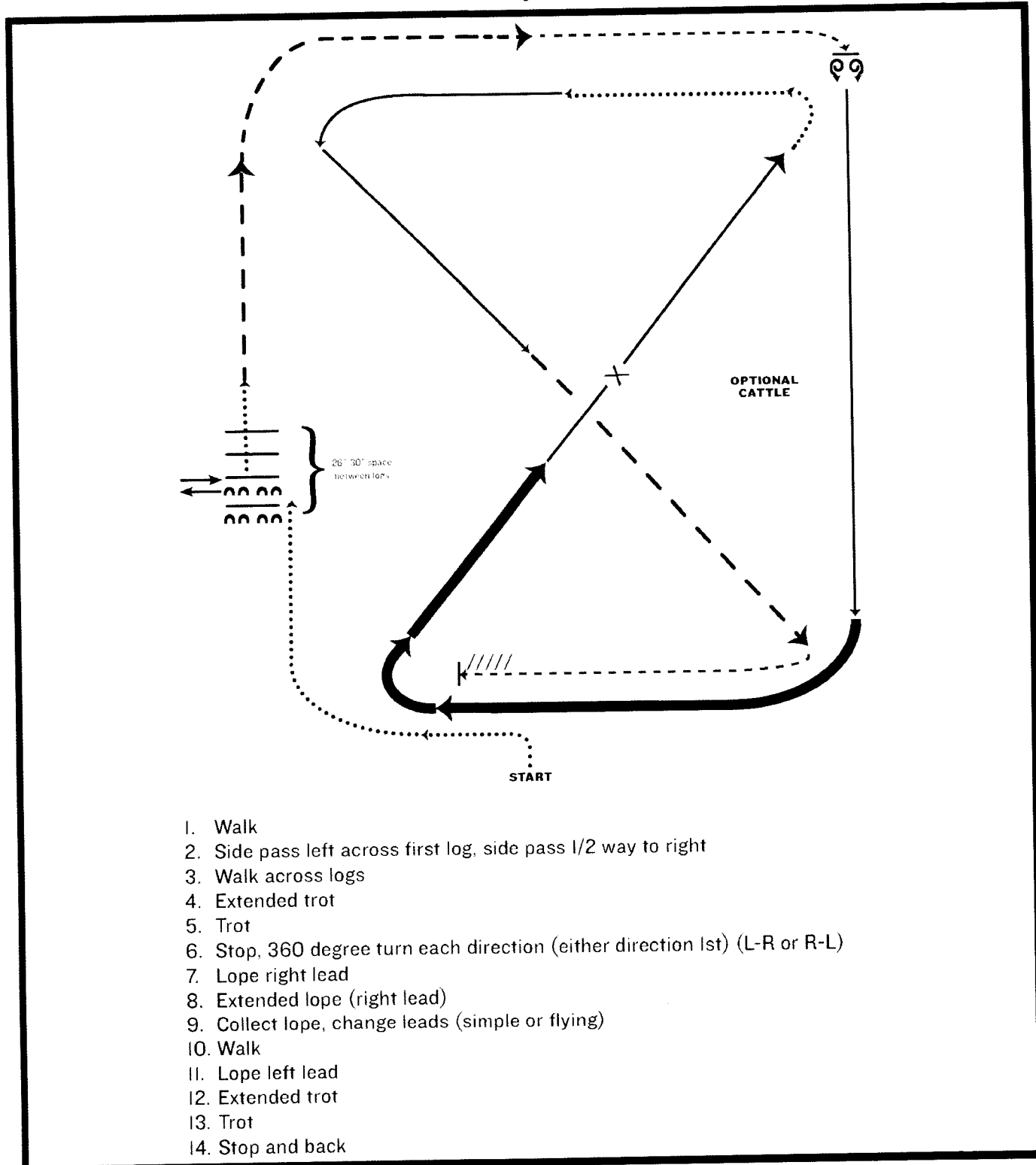

[RR/AQHA-8]

Pattern Provided by:

Judges

Dal-Worth ApHC Spring Spectacular

Green Western Riding (Green Pattern #438,439,440,)

Show Date:

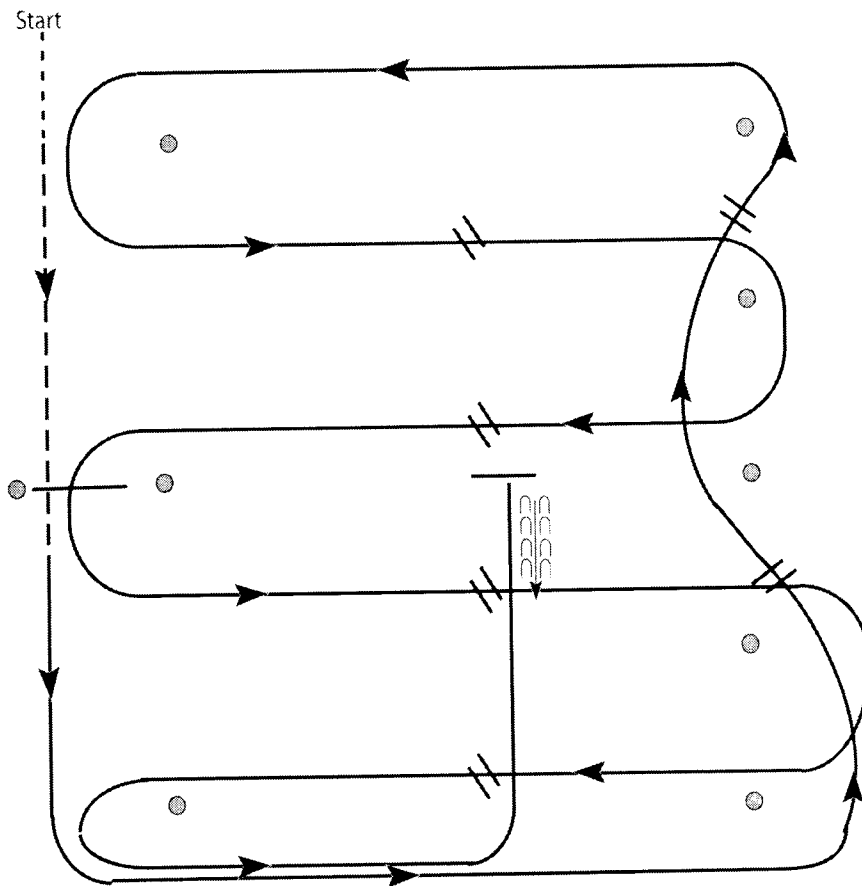

1. Walk at least 15' & jog over log.
2. Transition to left lead and lope around end.
3. First line change.
4. Second line change. Lope around end of arena
5. First crossing change.
6. Second crossing change.
7. Lope over log.
8. Third crossing change.
9. Fourth crossing change.
10. Lope up the center, stop and back.

[WR/GP-1]

Pattern Provided by:

Judges

Dal-Worth ApHC Spring Spectacular

Western Riding (#437. #441 through #449)

Show Date:

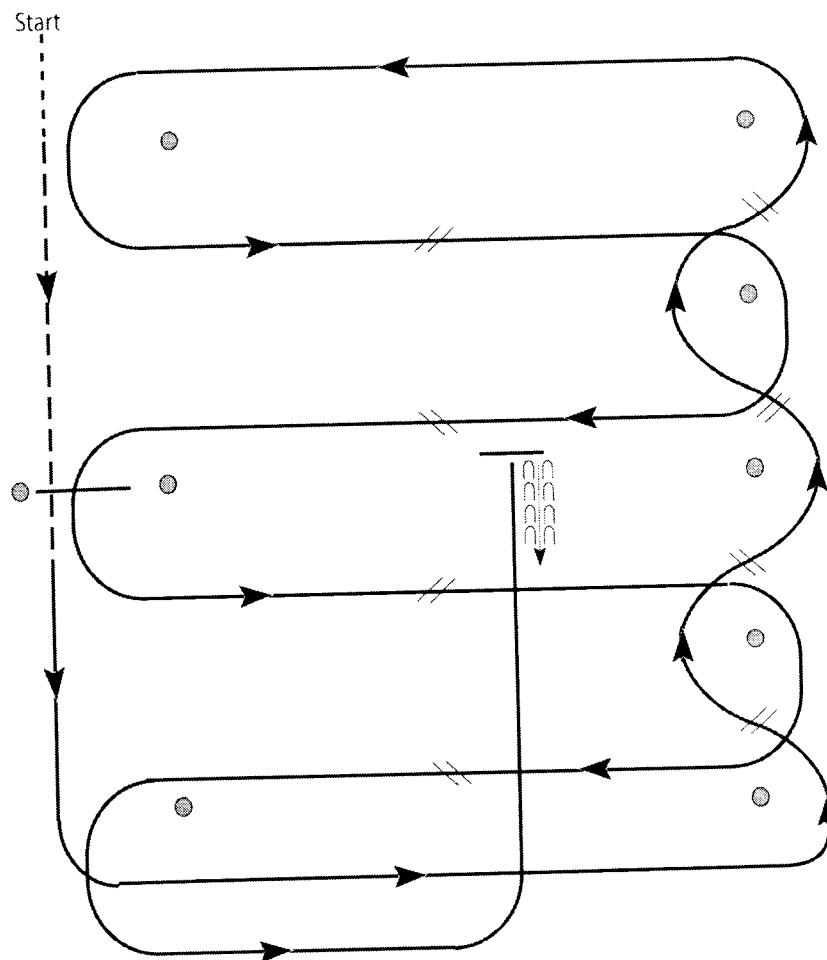

1. Walk and jog over log.
2. Transition to lope and lope around end.
3. First line change.
4. Second line change.
5. Third line change.
6. Fourth line change and lope around the end of the arena.
7. First crossing change.
8. Second crossing change.
9. Lope over log.
10. Third crossing change.
11. Fourth crossing change.
12. Lope up the center, stop and back.

[WR/OP-1]

Pattern Provided by:

Judges

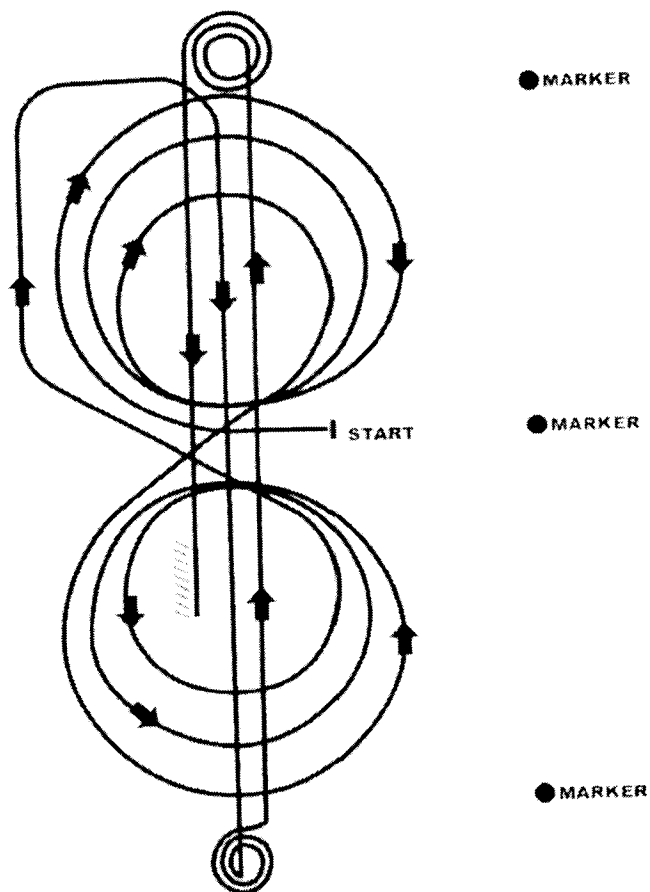

RANCH REINING PATTERN 3

Mandatory Marker along Fence or Wall: The judge shall indicate with markers on arena fence or wall the center of pattern. Judge shall also place markers on fence or wall at least 50' from each end of the arena.

Ride pattern as follows: Trot to center of arena and stop or walk before departure. Start pattern facing toward judge.

1. Beginning on right lead, complete three circles to the right - the first two large and fast; the third one small and slow. Change leads at center of arena.
2. Complete three circles to the left - the first two large and fast; the third one small and slow. Change leads at center of arena.
3. Begin a large circle to the right, but do not close this circle. Run down center of arena, past the end marker, and do a sliding stop.
4. Complete 3 1/2 spins to the right.
5. Run up center of arena to the opposite end, past the end marker, do a sliding stop.
6. Complete 3 1/2 spins to the left.
7. Run back to the middle of the arena, past the center marker, and do a sliding stop. Back up at least 10 feet. Hesitate to show completion of pattern.

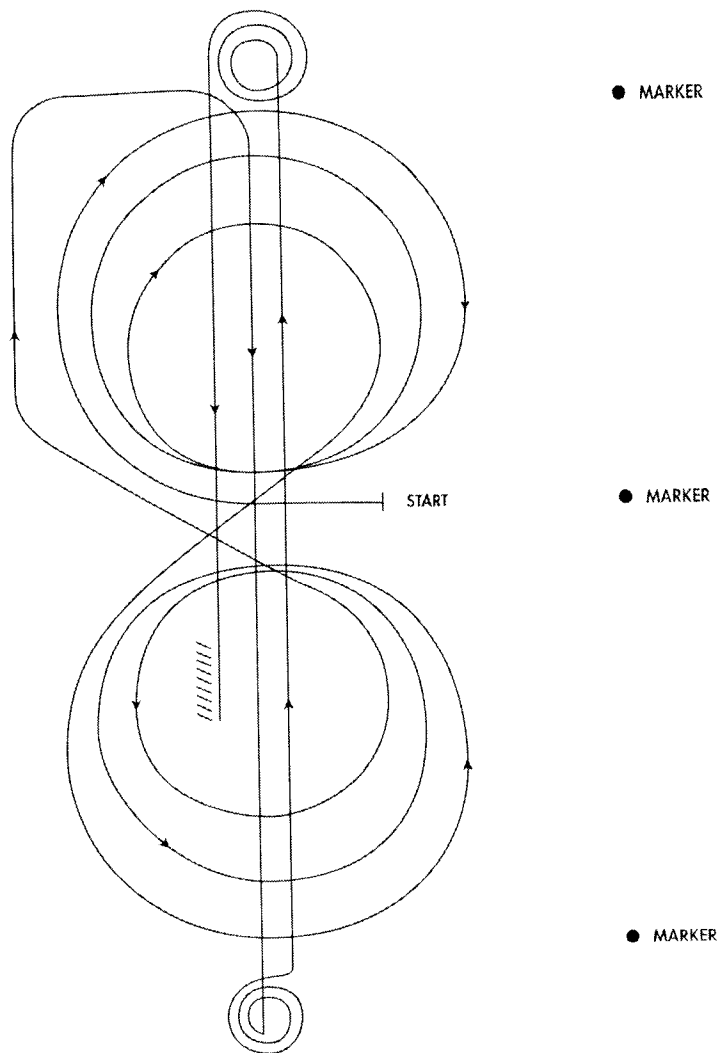

WORKING COW HORSE PATTERN #3

Trot to center of arena, stop. Start pattern facing toward judge.

1. Begin on right lead complete 3 circles to right (2 big fast circles followed by 1 small slow circle), change to left lead.
2. Complete 3 circles to left (first 2 big, fast circles followed by 1 small, slow circle). Change to right lead.
3. Continue loping around end of arena without breaking gait.
4. Run up center of arena to far end past the end marker and come to a sliding stop.
5. Complete **3 ½** spins to the right.
6. Run up center of arena past the end marker, come to a sliding stop.
7. Complete **3 ½** spins to the left.
8. Run back to middle of the arena past the center marker and come to a sliding stop.
9. Back 10 to 15 feet (3–4.57 m) in a straight line.
10. Hesitate to complete pattern.

Pattern 3

- | | |
|--------------------|---------------------|
| 1. Right circles | 5. Stop |
| 2. Left circles | 6. 3 ½ spins left |
| 3. Stop | 7. Stop and back up |
| 4. 3 ½ spins right | |

RANCH TRAIL

Walk trot

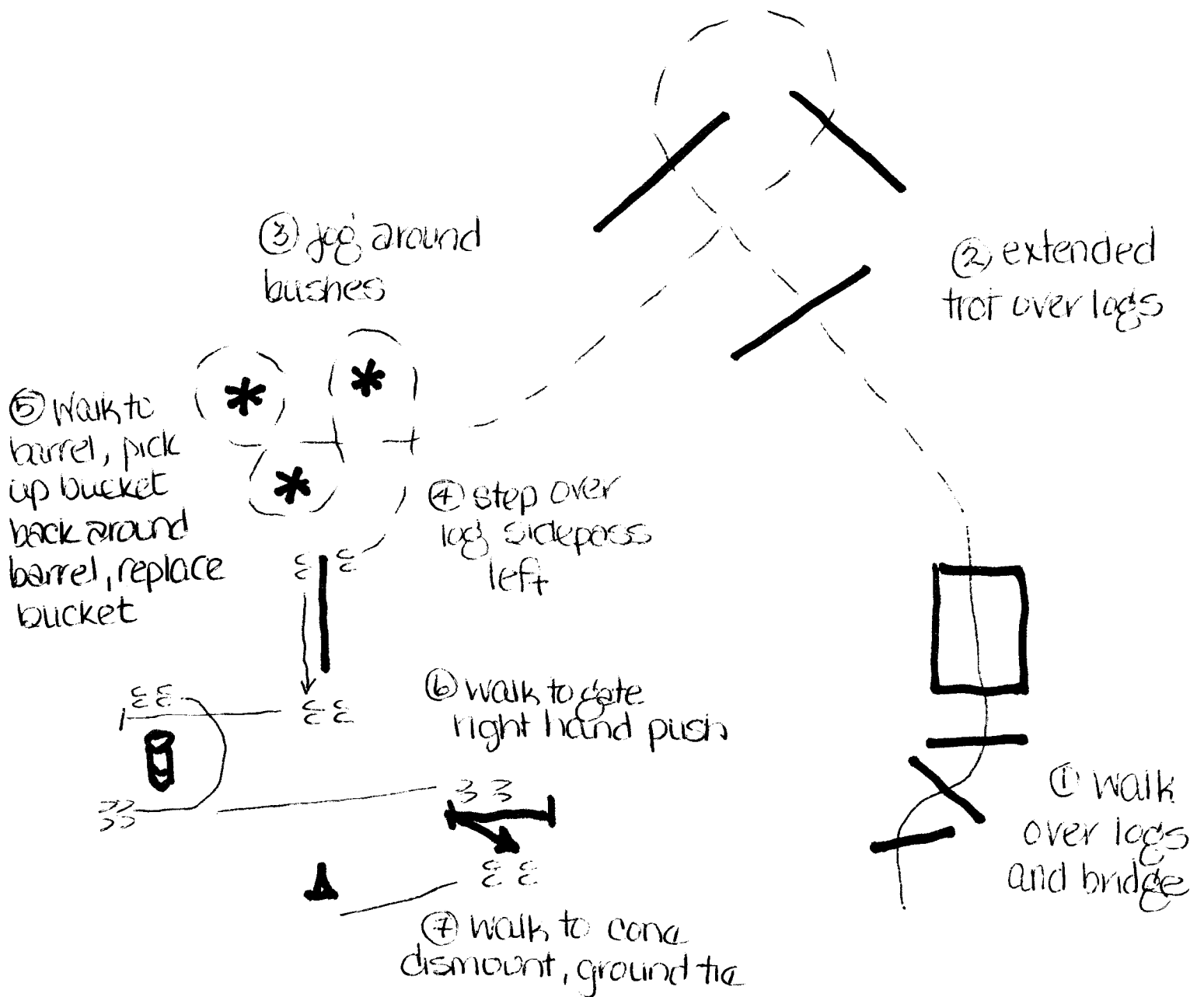

RANCH TRAIL

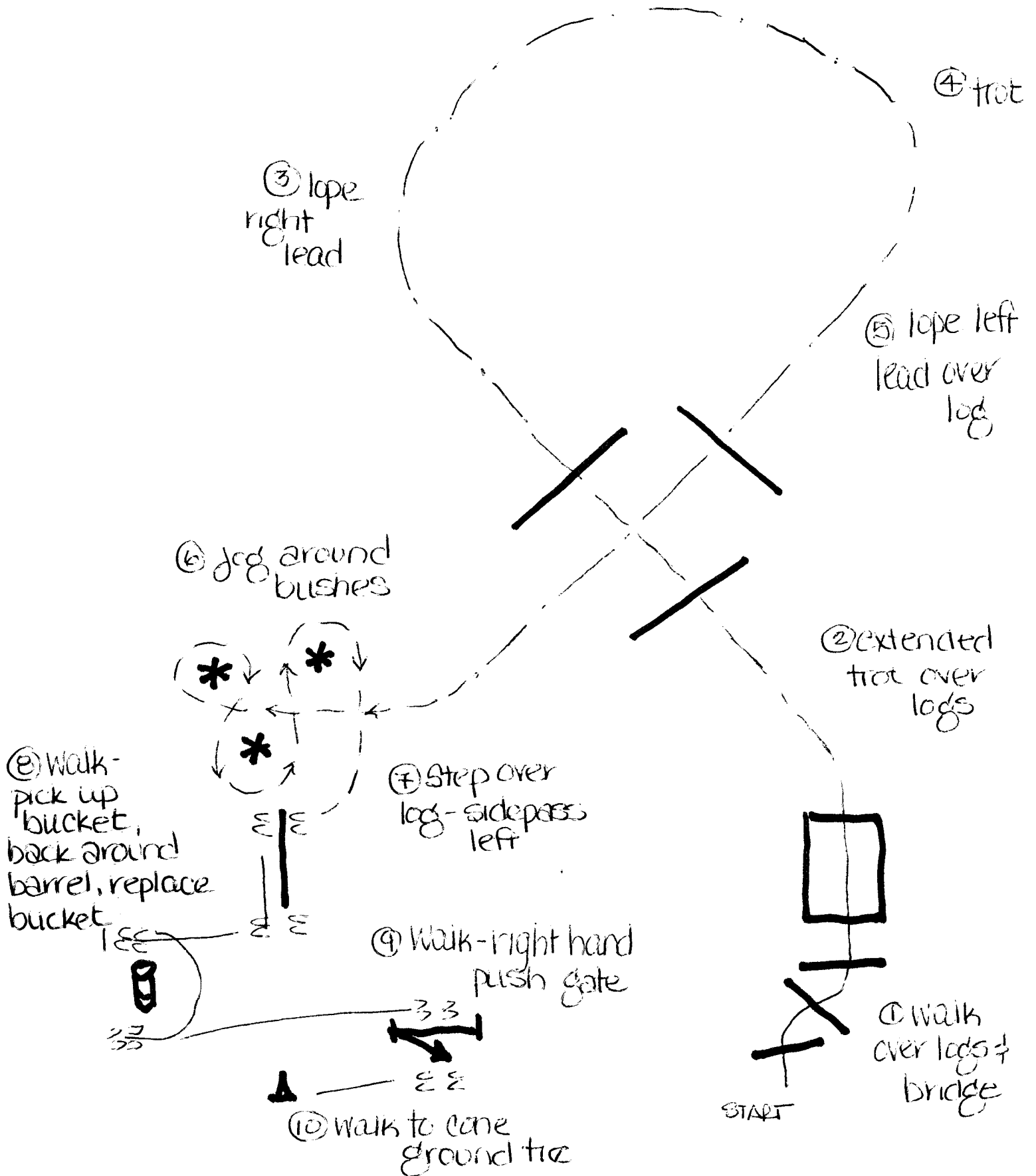

TRAIL

WALK TROT

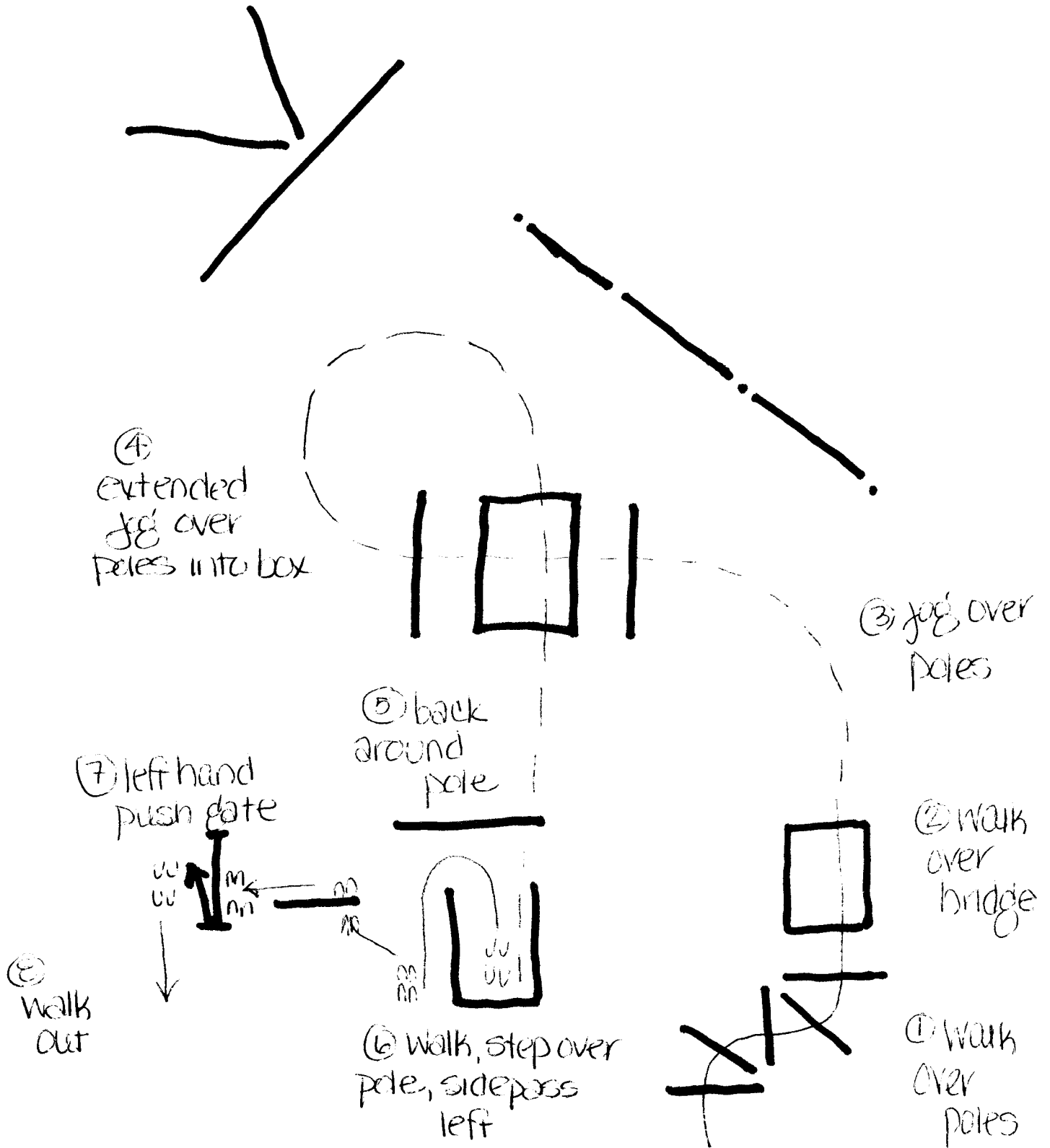

TRAIL

